

Our associates will ensure the tool works properly before you leave the store. If you experience issues with the tool while completing your project, simply bring it back to the Tool Rental Center to get a replacement. If you purchase Damage Protection at the time of your rental, you are not responsible for repair costs for tools that break due to normal use.



L1763 Rev I 03/09

Index:

English	1-7
Français	8-14
Deutsch	15-22
Italiano	23-29
Español	30-36
Nederlands	37-44
Portuguese	45-51
日本語	52-58
中文	59-64
Svenska	65-71
Greek	72-80
Finnish	81-87
Russian	88-95

Repair Parts Sheets for this product are available from the Enerpac web site at www.enerpac.com, or from your nearest Authorized Enerpac Service Center or Enerpac Sales office.

1.0 IMPORTANT RECEIVING INSTRUCTIONS

Visually inspect all components for shipping damage. Shipping damage is **not** covered by warranty. If shipping damage is found, notify carrier at once. The carrier is responsible for all repair and replacement costs resulting from damage in shipment.

SAFETY FIRST

2.0 SAFETY ISSUES



Read all instructions, warnings and cautions carefully. Follow all safety precautions to avoid personal injury or property damage during system operation. Enerpac cannot be responsible for damage or injury resulting from unsafe product use, lack of maintenance or incorrect product and/or system operation. Contact Enerpac when in doubt as to the safety precautions and operations. If you have never been trained on high-pressure hydraulic safety, consult your distribution or service center for a free Enerpac Hydraulic safety course.

Failure to comply with the following cautions and warnings could cause equipment damage and personal injury.

A **CAUTION** is used to indicate correct operating or maintenance procedures and practices to prevent damage to, or destruction of equipment or other property.

A **WARNING** indicates a potential danger that requires correct procedures or practices to avoid personal injury.

A **DANGER** is only used when your action or lack of action may cause serious injury or even death.



WARNING: Wear proper personal protective gear when operating hydraulic equipment.



WARNING: Stay clear of loads supported by hydraulics. A cylinder, when used as a load lifting device, should never be used as a load holding device. After the load

has been raised or lowered, it must always be blocked mechanically.



WARNING: USE ONLY RIGID PIECES TO HOLD LOADS. Carefully select steel or wood blocks that are capable of supporting the load. Never use a hydraulic cylinder as a shim or spacer in any lifting or pressing application.



DANGER: To avoid personal injury keep hands and feet away from cylinder and workpiece during operation.



WARNING: Do not exceed equipment ratings. Never attempt to lift a load weighing more than the capacity of the cylinder. Overloading causes equipment failure and possible personal injury. The cylinders are designed for a max. pressure of 700 bar [10,000 psi]. Do not connect a jack or cylinder to a pump with a higher pressure rating.



DANGER: Never set the relief valve to a higher pressure than the maximum rated pressure of the pump. Higher settings may result in equipment damage and/or personal injury. Do not remove relief valve.



WARNING: The system operating pressure must not exceed the pressure rating of the lowest rated component in the system. Install pressure gauges in the system to monitor operating pressure. It is your window to what is happening in the system.



CAUTION: Avoid damaging hydraulic hose. Avoid sharp bends and kinks when routing hydraulic hoses. Using a bent or kinked hose will cause severe back-pressure. Sharp bends and kinks will internally damage the hose leading to premature hose failure.



Do not drop heavy objects on hose. A sharp impact may cause internal damage to hose wire strands. Applying pressure to a damaged hose may cause it to rupture.



IMPORTANT: Do not lift hydraulic equipment by the hoses or swivel couplers. Use the carrying handle or other means of safe transport.



CAUTION: Keep hydraulic equipment away from flames and heat. Excessive heat will soften packings and seals, resulting in fluid leaks. Heat also weakens hose materials and packings. For optimum performance do not expose equipment to temperatures of 65 °C [150 °F] or higher. Protect hoses and cylinders from weld spatter.



DANGER: Do not handle pressurized hoses. Escaping oil under pressure can penetrate the skin, causing serious injury. If oil is injected under the skin, see a doctor immediately.



WARNING: Only use hydraulic cylinders in a coupled system. Never use a cylinder with unconnected couplers. If the cylinder becomes extremely overloaded, components can fail catastrophically causing severe personal injury.



WARNING: BE SURE SETUP IS STABLE BEFORE LIFTING LOAD. Cylinders should be placed on a flat surface that can support the load. Where applicable, use a cylinder base for added stability. Do not weld or otherwise modify the cylinder to attach a base or other support.



Avoid situations where loads are not directly centered on the cylinder plunger. Off-center loads produce considerable strain on cylinders and plungers. In addition, the load may slip or fall, causing potentially dangerous results.



Distribute the load evenly across the entire saddle surface. Always use a saddle to protect the plunger.



IMPORTANT: Hydraulic equipment must only be serviced by a qualified hydraulic technician. For repair service, contact the Authorized ENERPAC Service Center in your area. To protect your warranty, use only ENERPAC oil.



WARNING: Immediately replace worn or damaged parts by genuine ENERPAC parts. Standard grade parts will break causing personal injury and property damage. ENERPAC parts are designed to fit properly and withstand high loads.



CAUTION: Always use the handle to carry the pump. Carrying the pump by the hose may damage the hose and/or the pump.

SPECIFICATIONS – Use this instruction sheet for the following hand pump models.						
Hand Pump Specifications						
Model	Type (Speed)	Maximum Pressure Rating psi [bar]		Oil Volume per Stroke in ³ [cm ³]		Usable Oil Capacity in ³ [cm ³]
EHF-65	1	6,500 [440]		.16 [2.62]		22 [360]
P-18	1	2,850 [200]		.16 [2.62]		22 [360]
P-25	1	2,500 [170]		.58 [9.51]		231 [3786]
P-39, 1003	1	10,000 [700]		.16 [2.62]		43 [705]
P-50	1	5,000 [340]		.29 [4.75]		231 [3786]
P-51	1	3,000 [210]		.25 [4.09]		50 [820]
P-141, 1001	1	10,000 [700]		.055 [.90]		20 [328]
P-391, 1004	1	10,000 [700]		.151 [2.47]		55 [900]
		Stage 1	Stage 2	Stage 1	Stage 2	
P-80, 1006	2	350 [25]	10,000 [700]	.99 [16.23]	.15 [2.46]	140 [2295]
P-84	2	350 [25]	10,000 [700]	.99 [16.23]	.15 [2.46]	140 [2295]
P-142, 1002	2	200 [14]	10,000 [700]	.221 [3.62]	.055 [.90]	20 [328]
P-142AL	2	200 [14]	10,000 [700]	.221 [3.62]	.055 [.90]	9.0 [148]
P-202	2	200 [14]	10,000 [700]	.221 [3.62]	.055 [.90]	55 [900]
P-77	2	200 [14]	10,000 [700]	.63 [16.0]	.094 [2.41]	47 [769]
P-392, 1005	2	200 [14]	10,000 [700]	.687 [11.26]	.151 [2.47]	55 [900]
P-392AL	2	200 [14]	10,000 [700]	.687 [11.26]	.151 [2.47]	55 [900]
P-462	2	200 [14]	10,000 [700]	7.69 [126.00]	.29 [4.75]	462 [7572]
P-464	2	200 [14]	10,000 [700]	7.69 [126.00]	.29 [4.75]	462 [7572]
P-801	2	350 [25]	10,000 [700]	.99 [16.23]	.15 [2.46]	250 [4095]
P-802	2	400 [28]	10,000 [700]	2.40 [39.34]	.15 [2.46]	155 [2540]
P-842	2	400 [28]	10,000 [700]	2.40 [39.34]	.15 [2.46]	155 [2540]

3.0 DESCRIPTION

3.1 Models P-141, 1001; P-142, 1002; P-202; P-391, 1004; P-392, 1005; P-802; P-842

Figure 1 and the corresponding table show the main components of hand pump models P-141, P-142, P-202, P-391, P-392, P-802, and P-842. The dual-purpose vent/fill cap acts as a pressure relief valve in case of accidental reservoir pressurization. To provide an access port at the rear of the reservoir for remote valves, use a return-to-tank kit. See the Table 1 for kit model numbers.

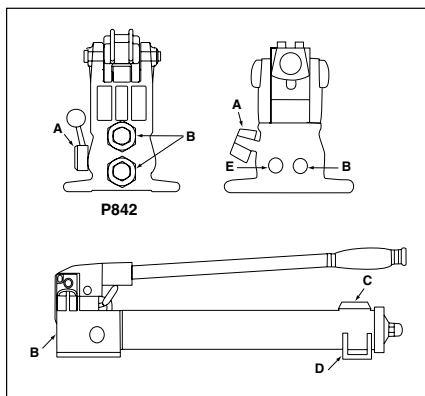

Figure 1

3.2 Models P-18/P-39, 1003/P-80, 1006/P-84/P-801, P-77

Figure 2 and the corresponding table below show the main components of these hand pump models. Model P-84 is equipped with a 4-way, 3-position valve for use with double-acting cylinders. To convert models P-18 or P-39 to foot operation, order Kit PC-10.

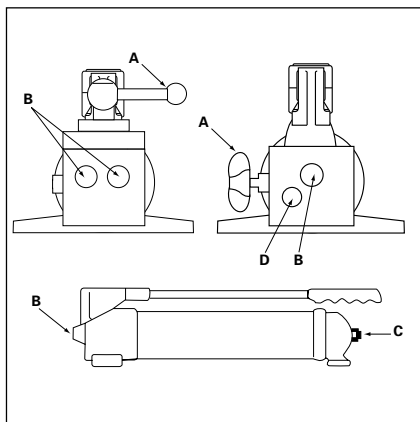

Figure 2



WARNING: These pumps are operated with a non-vented reservoir. If the reservoir is subjected to high pressure, the casing may rupture, causing personal injury and/or equipment damage. NEVER attempt to return more oil to the reservoir than it is capable of holding.

Table 1

Fig. 1	P-141, 1001	P-142, 1002	P-202	P-391, 1004	P-392, 1005	P-802	P-842
A	Release Valve	Release Valve	Release Valve	Release Valve	Release Valve	Release Valve	4-Way Valve
B	1/4 NPTF Outlet Port	1/4 NPTF Outlet Port	1/4 NPTF Outlet Port	3/8 NPTF Outlet Port	3/8 NPTF Outlet Port	3/8 NPTF Outlet Port	3/8 NPTF Outlet Port
C	Vent/Fill Cap	Vent/Fill Cap	Vent/Fill Cap	Vent/Fill Cap	Vent/Fill Cap	Vent/Fill Cap	Vent/Fill Cap
D	Mounting	Mounting Slots	—	—	—	Mounting Slots	Mounting Slots
E	—	—	—	—	—	Return-to-Tank Port	—
Return-to-Tank Kit	PC-20	PC-20	PC-25	PC-25	PC-25	—	—

Table 2

Fig. 2	P-18	P-39, 1003	P-77	P-80, 1006	P-84	P-801
A	Release Valve	Release Valve	Release Valve	Release Valve	Release Valve	Release Valve
B	3/8 NPTF Outlet Port	3/8 NPTF Outlet Port	3/8 NPTF Outlet Port	3/8 NPTF Outlet Port	3/8 NPTF Outlet Port	3/8 NPTF Outlet Port
C	Fill Plug	Fill Plug	Fill Plug	Fill Plug	Fill Plug	Fill Plug
D	—	—	—	1/4 NPTF Return-to-Tank Port	—	1/4 NPTF Return-to-Tank Port

3.3 Models P-462 and P-464

Figure 3 and the table below show the main features of hand pump models P-462, for use with single-acting cylinders, and P-464, for use with double-acting cylinders.

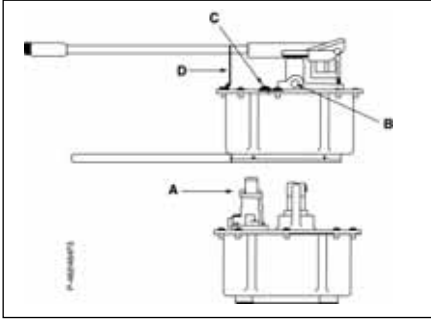

Figure 3, Models P-462, P-464

Table 3		
Fig. 3	P-462	P-464
A	3-Way 2-Position Valve	4-Way 3-Position Valve
B	3/8 NPTF Outlet Port	3/8 NPTF Outlet Port
C	Vent/Fill Plug	Vent/Fill Plug
D	Handle Clip	Handle Clip

3.4 Models P-25, P-50, and P-51

Figure 4 shows hand pump models P-25 and P-50, both of which are equipped with a handle that operates in both directions. Figure 5 shows the P-51 hand pump. The main components of these pumps are listed in the table below.

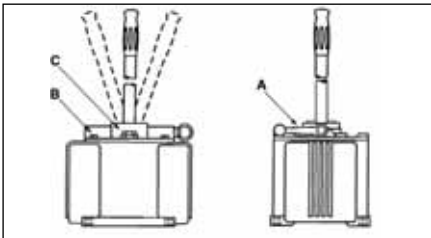

Figure 4, Models P-25 and P-50

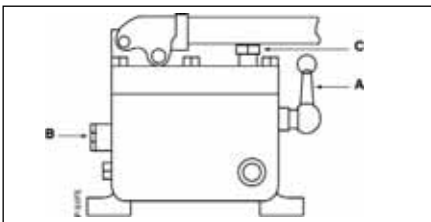

Figure 5, Model P-51

Table 4 and 5			
Fig. 4 & 5	P-25	P-50	P-51
A	Release Valve	Release Valve	Release Valve
B	1/4 NPTF Outlet Port	1/4 NPTF Outlet Port	1/4 NPTF Outlet Port
C	Vent/Fill Cap	Vent/Fill Cap	Vent/Fill Cap

4.0 INSTALLATION

4.1 Connecting the Pump

1. Thread hose into pump outlet. Use 1 1/2 wraps of Teflon tape (or suitable thread sealant) on hose fitting, leaving the first complete thread free of tape to ensure that tape does not shed into hydraulic system, causing damage. Trim loose ends.
2. Install a pressure gauge in-line from the pump for added safety and better control.
3. Connect the hose(s) to your cylinder or tool.

NOTE: For single-acting cylinders, connect one hose from the pump to the cylinder. For double-acting cylinders, connect two hoses. Connect one hose from the pressure port of the pump to the pressure port of the cylinder. Connect another hose from the retract port of the pump to the retract port of the cylinder.

4.2 Pump Venting

See table below to determine if your pump should be operated with a vented or non-vented reservoir. Vented pumps provide slightly better performance. For pumps with nylon reservoir, turn vent/fill cap 1/4 turn counter-clockwise to vent. For other pumps, see decal on pump. Close vent prior to transporting pump to prevent oil leakage. P-80, P-801, and P-84 are vented by turning the valve counterclockwise. To close the vent, turn the valve clockwise.

VENTING OPTIONS

EHF-65non-vented	P-202either
P-18non-vented	P-391, 1004either
P-25either	P-77vented
P-39, 1003non-vented	P-392, 1005 either
P-50either	P-392ALvented
P-51vented	P-462vented
P-80, 1006either	P-464vented
P-84either	P-801non-vented
P-141, 1001either	P-802either
P-142, 1002either	P-842either
P-142ALnon-vented	

4.3 Pump Position

See table below to determine the correct operating position for your pump, horizontal or vertical. The P-80, P-801, and P-84 cannot be vented when operated vertically.

OPERATING POSITION

EHF-65 either	P-202 either
P-18 either	P-391, 1004 either
P-25 horizontal only	P-77 either
P-39, 1003 either	P-392, 1005 either
P-50 horizontal only	P-392AL either
P-51 horizontal only	P-462 ... horizontal only
P-80, 1006 either	P-464 ... horizontal only
P-84 either	P-801 either
P-141, 1001 either	P-802 either
P-142, 1002 either	P-842 either
P-142AL either	

NOTE: When operating the pump in the vertical position, the hose end must be pointed down, or the pump will pick up air and will not build pressure properly.

5.0 OPERATION

5.1 Before Using the Pump

1. Check all system fittings and connections to be sure they are tight and leak free.
2. Check oil level in reservoir before operating pump. See "Adding Oil to the Pump" on page 7.



CAUTION: NEVER add extensions to pump handle. Extensions cause unstable pump operation.



WARNING: In certain situations the pump handle can "kick back". Always keep your body to the side of the pump, away from the line of force of the handle.

NOTE: To reduce handle effort at high pressure, take short strokes. Maximum leverage is obtained in the last 5° of stroke.

5.2 Using Two-Speed Pumps

These pumps provide 2-stage flow. Under no-load, the pump operates in the high flow first stage for rapid advance. When the load is contacted, the pump automatically shifts to the second stage for building pressure. For **P-462 or P-464 models**, when pump pressure reaches approximately 200 psi [14 bar], you must momentarily stop pumping and raise the handle to shift to the high pressure stage. For **P-802 or P-842 models**, when pump pressure reaches approximately 400 psi [28 bar], you must momentarily stop pumping and raise the handle to shift to the high pressure stage. After the pump shifts, pumping takes less effort.

NOTE: For best performance, operate pump handle at moderate speed during the high flow first stage. Rapid handle speed in the first stage will prevent the pump from delivering full volume of oil.

5.3 Single-Acting Applications with Release Valve

1. Close release valve by turning clockwise, as shown in Figure 6.

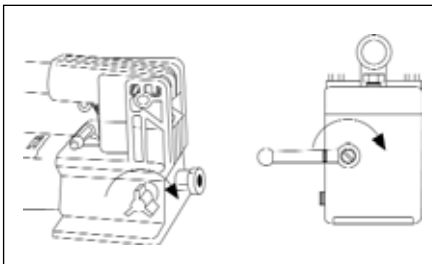

Figure 6



CAUTION: Close release valve finger tight ONLY. Using tools on release valve can damage it and cause the pump to malfunction.

2. Operate pump handle to deliver hydraulic power to system. Pressure will be maintained until release valve is opened.
3. Open release valve (turn counter-clockwise) to release pressure, allowing oil to flow back to the reservoir.

5.4 Single-Acting Applications with 3-Way, 2 Position Manual Valve

1. Shift valve handle to position 1 as shown in Figure 7.
2. Operate pump handle to deliver hydraulic power to the system. Pressure will be maintained until the valve is shifted.
3. To allow oil to return to the reservoir, shift valve handle to position 2.

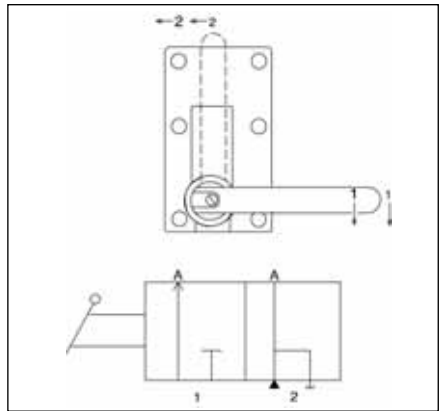

Figure 7

5.5 Double-Acting Applications with 4-Way, 3 Position Manual Valve

Pumps with 4-way control valves are designed to operate double-acting cylinders. See Figure 8 for valve positions.

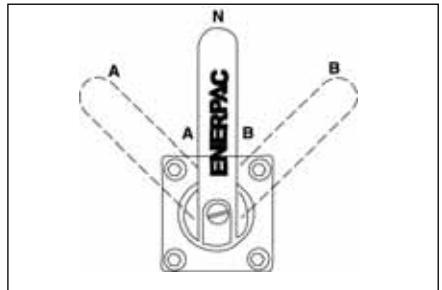

Figure 8a

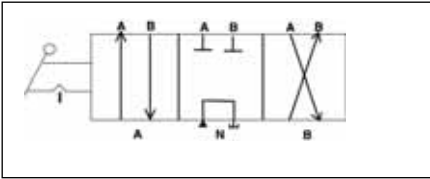

Figure 8b

1. Position lever on 4-way valve to select function as follows:
 - (A) Flow to Port "A"; port "B" returns flow to the reservoir
 - (N) Neutral; ports "A" and "B" are blocked
 - (B) Flow to port "B"; port "A" returns flow to the reservoir

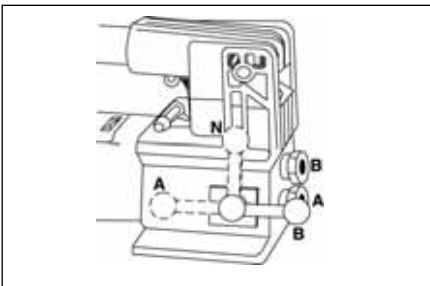

Figure 8c

2. Operate pump to perform work.
3. Change valve positions as needed.



WARNING: Operate double-acting cylinder only when both hoses are connected to the pump. If one coupler is left unconnected, high pressure will build behind the coupler which could cause personal injury and/or equipment damage.

5.6 Relief Valve Adjustment

All pumps contain a factory set relief valve to prevent over-pressurization of the system. Lower pressure settings can be obtained. Contact your Authorized Enerpac Service Center.

6.0 AIR REMOVAL

Removing air from the hydraulic system will help the cylinder to advance and retract smoothly (see figure 9).

6.1 Pump With Single-Acting Cylinder (A)

1. Vent pump reservoir (for vented pumps only) and close release valve.
2. Position pump at higher elevation than cylinder.
3. Position cylinder with the plunger end down (up if using pull cylinder). See Figure 9 below.
4. Operate pump to fully extend the cylinder (retract if using pull cylinder).
5. Open release valve to retract cylinder (extend if a pull cylinder). This will force the trapped air to move up to the pump reservoir.
6. Repeat the above steps as necessary.
7. Add oil if necessary. See page 7.
8. Return vent/fill cap to operating position.

6.2 Pump With Double-Acting Cylinder (B)

1. Vent pump reservoir (for vented pumps only).
2. Position pump at higher elevation than cylinder.
3. Put cylinder in horizontal position with ports up. See Figure 9.
4. Fully advance and retract the cylinder 2 to 3 times.
5. Repeat the above steps as necessary.
6. Add oil if necessary. See page 7.
7. Return vent/fill cap to operating position.

7.0 MAINTENANCE

Use only Enerpac hydraulic oil with these pumps to promote long pump life and to protect your warranty. Viton and EPR seal kits are available for some hand pumps. Contact your Enerpac representative for more information on these products and their applications.

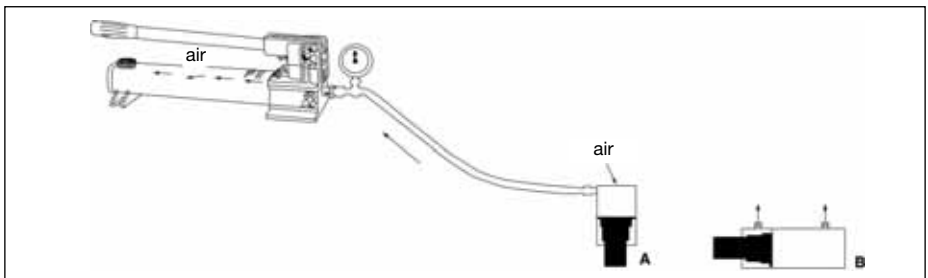

Figure 9

7.1 Adding Oil to the Pump

Check oil level regularly.



WARNING: Always add oil with cylinders fully retracted (extended if pull cylinders) or the system will contain more oil than the reservoir can hold.

1. Remove vent/fill cap from reservoir.
2. Fill reservoir only to level mark shown on pump.
3. Remove air from system if necessary. See page 6. Recheck oil level after removing air.
4. Return vent/fill cap to proper position.

NOTE: Non-vented hand pumps require air in the reservoir to function properly. If the reservoir is completely filled, a vacuum will form preventing oil from flowing out of the pump.

7.2 Keeping Oil Lines Clean

When coupler halves are disconnected, always screw on dust caps. Use every precaution to guard unit against entrance of dirt because foreign matter may cause pump, cylinder, or valve failure.

7.3 Lubricating the Pump

To extend pump life and improve performance, lubricate the beam pin (A), cross pin (B), and piston head (C) regularly, using roller bearing grease. See Figure 10.

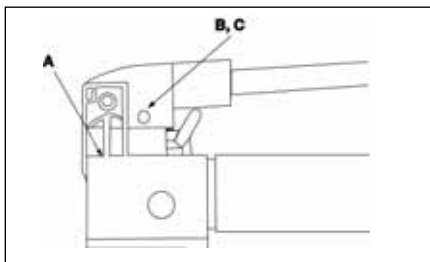

Figure 10

7.4 Changing the Oil

1. Drain all oil and refill with clean Enerpac oil every 12 months. If pump is used in dirty environments, change the oil more often.
2. Remove vent/fill cap or plug from reservoir.
3. Tilt pump to drain out old oil.
4. Fill reservoir only to level mark shown on pump.
5. Replace the vent/fill cap or plug.
6. Dispose of used oil properly.

8.0 TROUBLESHOOTING GUIDE

The following information is intended as an aid in determining if a problem exists. For repair service, contact the Authorized Enerpac Service Center in your area.

TROUBLESHOOTING		
Problem	Possible Cause	Solution
Cylinder does not advance, advances slowly, or advances in spurts.	<ol style="list-style-type: none"> 1. Oil level in pump reservoir is low. 2. Release valve open. 3. Loose hydraulic coupler. 4. Load is too heavy. 5. Air trapped in system. 6. Cylinder plunger binding. 	<ol style="list-style-type: none"> 1. Add oil according to the Maintenance instructions on page 6. 2. Close the release valve. 3. Check that all couplers are fully tightened. 4. Do not attempt to lift more than rated tonnage. 5. Remove air according to the instructions on page 6. 6. Check for damage to cylinder. Have cylinder serviced by a qualified hydraulic technician.
Cylinder advances, but does not hold pressure.	<ol style="list-style-type: none"> 1. Leaking connection. 2. Leaking seals. 3. Internal leakage in pump. 	<ol style="list-style-type: none"> 1. Check that all connections are tight and leak free. 2. Locate leak(s) and have equipment serviced by a qualified hydraulic technician. 3. Have pump serviced by a qualified hydraulic technician.
Cylinder does not retract, retracts part way, or retracts more slowly than normal.	<ol style="list-style-type: none"> 1. Release valve closed. 2. Pump reservoir is over-filled. 3. Loose hydraulic coupler. 4. Air trapped in system. 5. Hose I.D. too narrow. 6. Cylinder retraction spring broken or other cylinder damage. 	<ol style="list-style-type: none"> 1. Open release valve. 2. Drain oil level to full mark. See page 7 instructions for adding oil. 3. Check that all couplers are fully tightened. 4. Remove air according to the instructions on page 6. 5. Use larger diameter hydraulic hose. 6. Have cylinder serviced by a qualified hydraulic technician.